



SECURITY'LIGHT
connected camera concept



ELARA
5267102118

LUTEC
CONNECTED BY LIGHTING

Contents



x 1

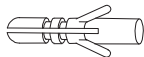

x 3



x 3



x 1



x 1

Introduction

INCL.
220-240V
~50Hz
LED 18W



IP44

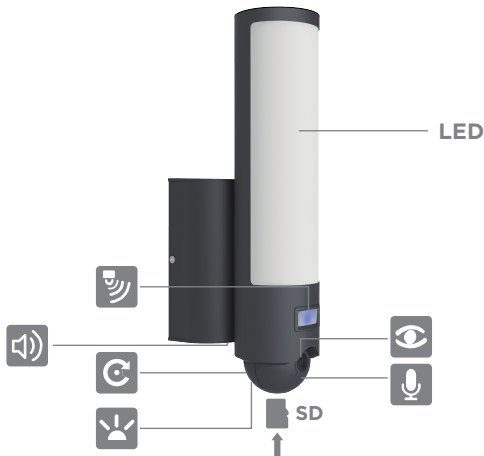

Reset
Réinitialiser
Reset
Ripristino
Reiniciar
Reset
Törlés
Reset



Camera
Camera
Kamera
Telecamera
Cámara
Camera
Kamera
Kamera



Microphone
Micro
Mikrofon
Microfono
Mikrófono
Microfoon
Mikrofon
Mikrofon



Loudspeaker
Haut parleur
Lautsprecher
Altoparlante
Altavoz
Luidspreker
Hangszóró
Głośnik



Sensor
Capteur
Bewegungsmelder
Sensore
Sensor
Sensor
Mozgásérzékelő
Czujnik



Indicator light
Témojn lumière
Luce indicatore
Luz indicadora
Indicatielampje
Visszajelző fény
Lampka kontrolna

Pre-installation

1



- Download the APP.
- Télécharger l'application.
- Laden Sie die APP herunter.
- Scaricare l'APP.
- Descargar la APP.
- Download de APP.
- Töltse le az applikációt.
- Pobierz aplikacje.

2



SECURITY'LIGHT

- Ensure **SECURITY'LIGHT** location has good Wi-Fi reception.
- S'assurer de la qualité de réception du WI-FI à l'emplacement du **SECURITY'LIGHT**.
- Stellen Sie sicher, dass die **SECURITY'LIGHT** Leuchte einen guten Wi-Fi-Empfang hat.
- Assicurarsi che la **SECURITY'LIGHT** sia in una posizione con buona ricezione Wi-Fi.
- Asegúrese de que **SECURITY'LIGHT** tiene buena recepción de Wi-Fi.
- Zorg ervoor dat de locatie van de **SECURITY'LIGHT** een goede WiFi ontvangst heeft.
- Győződjön meg róla, hogy a **SECURITY'LIGHT** jó Wi-Fi vétellel rendelkezzon
- Upewnij się **SECURITY'LIGHT** dobrze odbiera sygnał Wi-Fi.

Maintenance

- Wipe the camera regularly.
- Nettoyer régulièrement la camera
- Säubern Sie die Kamera regelmäßig.
- Spolverare la telecamera regolarmente.
- Limpie la cámara regularmente.
- Veeg de camera regelmatig schoon.
- Tisztítsa meg rendszeresen a kamera optikáját
- Przecieraj kamere regularnie.



- Via the "Support" button you can access to all further questions.
- Pour toute question complémentaire, touchez « Support ».
- Über den Button "Support" in der App finden Sie weitere Hinweise.
- Tramite il tasto "Support" puoi avere accesso a tutte le altre informazioni
- Mediante el botón de "Support" se puede acceder a las preguntas.
- Via de "Support" toets kan je toegang krijgen tot alle verdere informatie.
- A support/támogatás gomb segítségével minden további kérdésre választ kaphat.
- Poprzez guzik „Pomoc” możesz mieć dostęp do wszystkich dalszych pytań.

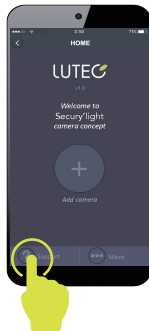



SECURITY'LIGHT
connected camera concept

*«When light meets a camera,
when light means security»*

Service:

LUTEC in FRANCE
+33-04-75602598

LUTEC in IBERIA
+34-93-5001221

LUTEC in ROMANIA
+40-234-562-452

LUTEC in UKRAINE
+38-044-496-74-83

LUTEC Europe NV
Ruiterschool 14 B-2930 Brasschaat - Belgium
+32 3 284 51 62

For more information, please visit:
www.lutec.com/services/global-network

LUTEC in UK
+44 (0) 1992-760870

LUTEC in BNL
+ 32 (0) 3-454-01-09

LUTEC in RUSSIA
+7-499-5501529

LUTEC in DACH-ECO-LIGHT Leuchten GmbH
+49-228-9691090 Böheler Weg 27 - D-53347 Alfter

LUTEC in ITALY
+39-031-3551342

LUTEC in HUNGARY
+36-30-2193952

LUTEC in GREECE
+30-2104820946

LUTEC

CONNECTED BY LIGHTING

Installation

① OFF

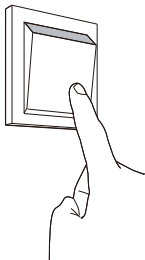

②

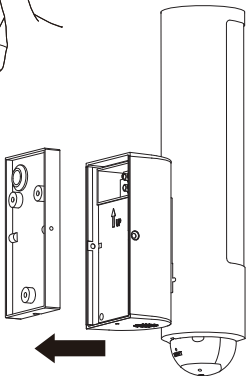
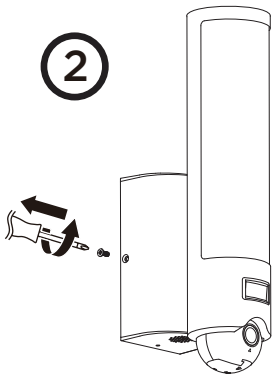

③

Installation

4

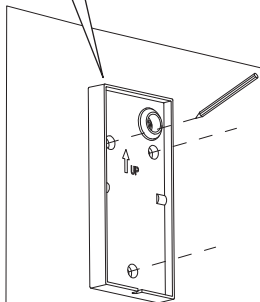
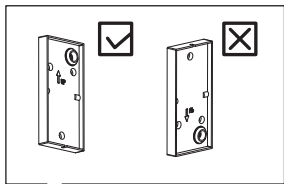
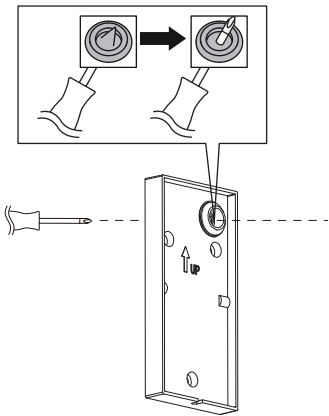

5

Installation

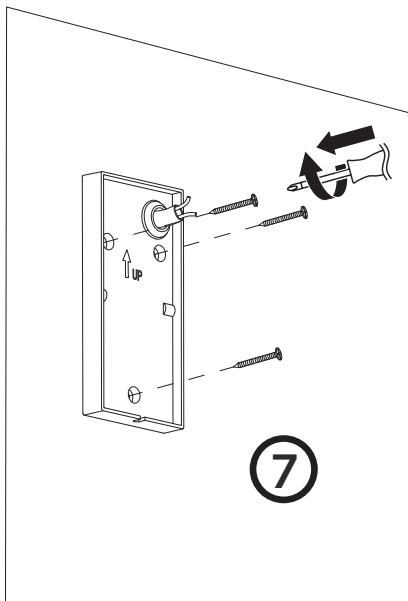
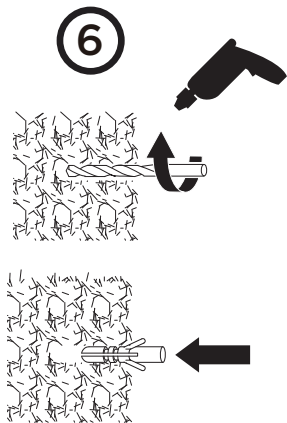

Installation

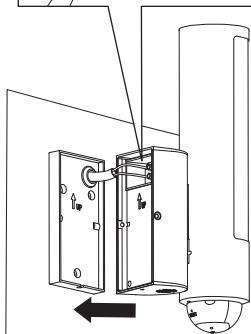
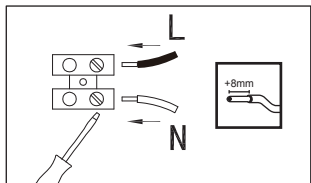

8

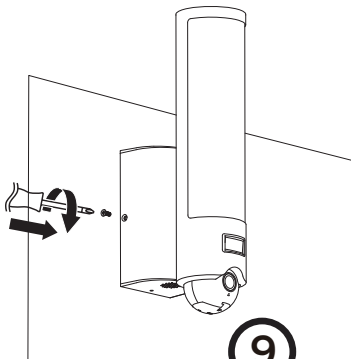

9

ON

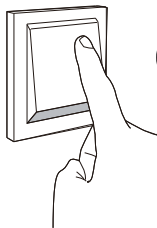

10

Adjustment

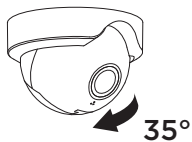
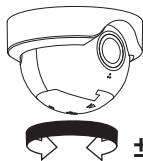
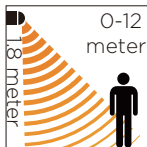
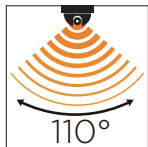
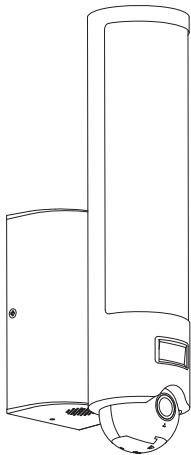

Set up



- Start set up when red indicator flashes.
- Commencer à configurer quand le témoin rouge clignote.
- Starten Sie die Installation während die rote Led blinkt.
- Mentre spia rossa è lampeggiante inizia a impostare.
- Inicie la configuración mientras el indicador rojo parpadee.
- Start de configuratie wanneer het rode lampje knippert.
- Kezdje el a beállításokat, ha a piros visszajelző fény villog
- Rozpocznij konfigurację kiedy czerwona lampka świeci.

